

# CULTIVATION OF PLANTS UNDER ARTIFICIAL ENVIRONMENTAL PARAMETERS TO INCREASE PRODUCTIVITY RATE

1.K. SIVA BHAVANI, 2.B.SAI RUCHITHA,3. S. SUSHMA,4. S. ANJALI

1.ASSISTANT PROFESSOR, 2,3&4.UG SCHOLAR

DEPARTMENT OF IOT, MALLA REDDY ENGINEERING COLLEGE FOR WOMEN, HYDERABAD

## ABSTRACT

In 2017, according to FAO, agricultural productivity is increasing at a rate of 1.5% per year which is nearly 1% lesser than the early 2000's. But the growth rate of population in India is 1.9% per annum according to the 2001 census. This means that we are in desperate need for increase in productivity to suffice our population. In this thesis, an automated greenhouse was built for checking the stability of the factors necessary for a plant's growth. This project uses three sensors- soil moisture sensor to keep track of the moisture, temperature and humidity sensor to monitor the weather and LDR to check the presence of light. There are three actuators- a cooling fan, DC pump and a light bulb. Results showed that when all the factors of plant growth are stabilized, then it is possible to grow a plant in 50 days which normally takes 80 days for its growth.

## INTRODUCTION

The climatic conditions may prevent the growth of certain plants in certain areas. So, there arises a need to import fruits or vegetables at a higher price. The key aim of modern agriculture is to enhance the growth of the plants for a maximum yield. Greenhouse does justice to this by replicating a different climate and constantly grow food in a larger proportion. It maintains the microclimatic parameters in a correct ratio as per the requirement of the plants. It has also reduced the labor for the maintenance thus making the system useful for the small scale agriculturists. This paper proposes the adoption and control of soil moisture, temperature, humidity, light intensity using sensors and actuators. The main purpose of this project is to grow crops anywhere, however the climatic parameters be. Usage of greenhouse replicates different climatic conditions, allowing the crops to grow that are not meant to be cultivated in that area. Meanwhile making the greenhouse automated makes it much easier to monitor and control the growth of crops. This

proposed system is used for a single plant cultivation and can be developed for mass production. Our proposed system is economical, portable and has low maintenance which can be incorporated in rural area.

## LITERATURE SURVEY

**Sun Rong-Gao, Sun De-Chao, “Greenhouse Temperature and Humidity Intelligent Control System”, ‘Proceeding of 3rd WSEAS international Conference on Circuits, Systems, Signal and Telecommunication’2009.**

In recent survey of FAO, the plant growth rate in India is 1.9% but agricultural productivity is 1%. According to this survey, upcoming years of 21st century in India the food is inadequate for the continuous growth in population. To overcome this problem, there is a need to keep track of necessary conditions and parameters, which are required for plant growth and increases productivity. Hence, we came up with a solution by using sensors like soil moisture sensor to keep track of the moisture, temperature and humidity sensor to monitor the weather and LDR to check the presence of light. There are actuators like a cooling fan, DC pump and a light bulb to

maintain artificial environmental conditions. Result shows that it is possible to grow a plant as early as possible, when compare to normal growth of plant in natural environmental conditions. Through IoT cloud base, the continuous monitoring of changes in environmental parameters and able to modify them and make sure that increase in productivity. The climatic conditions may prevent the growth of certain plants in certain areas. So, there arises a need to import fruits or vegetables at a higher price. The key aim of modern agriculture is to enhance the growth of the plants for a maximum yield. Greenhouse does justice to this by replicating a different climate and constantly grow food in a larger proportion. It maintains the microclimatic parameters in a correct ratio as per the requirement of the plants. It has also reduced the labor for the maintenance thus making the system useful for the small scale agriculturists. This paper proposes the adoption and control of soil moisture, temperature, humidity, light intensity using sensors and actuators. The main purpose of this project is to grow crops anywhere, however the climatic parameters be. Usage of greenhouse replicates different climatic conditions, allowing the crops to grow that are not meant to be cultivated

in that area. Meanwhile making the greenhouse automated makes it much easier to monitor and control the growth of crops. This proposed system is used for a single plant cultivation and can be developed for mass production. Our proposed system is economical, portable and has low maintenance which can be incorporated in rural area.

**Sumit, K; Mohit; K; Aswani, K. and Praneet, G. 2012. Monitoring and Control of Greenhouse Environment. B.Eng. Project, Department of Electrical and Electronics Engineering, Bharat Institute of Technology, Meerut, India.**

Climate change has resulted in unpredictable weather conditions, resulting in a global food deficit. A feasible solution to this problem would be for households to grow a reasonable percentage of their veggies and crops in a greenhouse that does not require a lot of land. When compared to open field gardening, a greenhouse will often produce more crops per square metre because the microclimatic parameters that impact crop output are continuously monitored and controlled to guarantee that an optimal environment is maintained. The greenhouse system is made up of two greenhouses:

Electronic circuits is installed in the first greenhouse(G1) and the second greenhouse is devoid of electronic Circuits (G2). Therefore, a program was designed to know and control the environmental conditions inside the greenhouse(G1). The system was created and tested on a smaller scale. For that, seedlings of cantaloupe (Cucumis melo) were grown in both greenhouses. Germination percentage, speed of germination, length of seedling, the seedling vigor index (G1), (G2), 98.8, 91.6 percent, 1.3, 1.7 days, 8.4, 6.6 cm, and 14,10 cm respectively. greenhouses are prefabricated structures that may be used for a long time and are covered with glass translucent polythene and shade net to grow seedlings of vegetables, spices, and flower crops. Protected cultivation is the process of altering the natural environment in order to promote crop growth and output. Artificially regulating temperature, humidity, and light to meet the needs of the crop in order to boost agricultural yield and extend the growth season. For the expansion of horticulture industry availability of quality planting material is the basic need (Singh, et al., 2017). Greenhouses used in Egypt on an increasingly large scale for early production of warm season vegetable, fruit and flowers.

In Egypt, numbers of greenhouses reached 62421 greenhouses with area reached 6344 feddans, according to (Agriculture Directorates of Governorates, Vegetable Affairs Sector, 2020). Greenhouses with appropriate mechanisms for controlling environmental conditions are required to produce agricultural plants throughout the year. People's lives are becoming increasingly intelligent. Agriculture is on its way to becoming more sophisticated. When the Android system is used to control the greenhouse climate, it can boost crop yield, lower greenhouse energy consumption, and lower labour costs (Zhao, et al., 2017). Sumit, et al., (2012) Use an embedded system that continuously analyses the microclimatic parameters of a greenhouse and activates actuators when safe thresholds are surpassed, restoring optimum conditions. Their design incorporates a Liquid Crystal Display (LCD) that is directly connected to a microcontroller, ensuring that the user is always informed on the state of the greenhouse. Obviously, a system like this can only offer information to the user about the conditions within the greenhouse while the user is physically present. Mahmoud and Ala'a (2013) It is discussed a Wireless Sensor Network (WSN) with smart watering

capacity. When the moisture level lowers, this device monitors the microclimatic factors around each row of crops and activates the appropriate irrigation pumps. Using electronic circuitry and programming, this technology creates ambient conditions for seedling growth within greenhouses. For greenhouse environment control, an intelligent close loop control system based on model embedded deep reinforcement learning (MEDRL) has been developed. Computer vision algorithms are utilised to recognise crop growing periods and sex, which are then used to train crop growth models with different growing times and sex. These model outputs, together with the cost factor, generate real-time greenhouse setpoints that are fed back to the control system. When compared to traditional greenhouse management procedures, the entire MEDRL system has the power to undertake optimization control precisely and conveniently, and expenses will be considerably lowered. Zhang, et al.,(2019) they mentioned that the greenhouses for greenhouse environment control, an intelligent close loop control system based on model embedded deep reinforcement learning (MEDRL) has been developed. Computer vision algorithms are utilised to

recognise crop growing periods and sex, which are then used to train crop growth models with different growing times and sex. These model outputs, together with the cost factor, generate real-time greenhouse setpoints that are fed back to the control system. When compared to traditional greenhouse management procedures, the entire MEDRL system has the power to undertake optimization control precisely and conveniently, and expenses will be considerably lowered. Progressive farmers are now cultivating high-value crops and flowers under commercially protected conditions (Maitra, et al., 2020). Nursery management is a vital aspect of ensuring a steady supply of disease-free early seedlings, especially for highvalue vegetables and flowers, which require special attention. For a nursery with a convey size of 1000 m<sup>2</sup> in a greenhouse. Commercial nursery business is becoming a highly successful industry for experienced farmers that cultivate vegetable seedlings and sell them to various areas. Vegetable and flower seeds are transplanted types of crop that require a single location to grow with better care and are then transplanted to the main field after a few days (Mohanta, et al., 2020).

**Rahali, A; Guerbaoui, M; Ed-dahhak, A; El Afou, Y; Tannouche, A; Lachhab, A. and Bouchikhi, B. 2011. Development of Data Acquisition and Greenhouse Control System based on GSM. International Journal of Engineering, Science and Technology, 3(8): 297-306.**

This paper explains the design and implementation of electronic system based on GSM (Global System for Mobile communication) for controlling the climate parameters by SMS (Short Message Service) in greenhouse. The main purpose of this system conception is the remote control of the climatic parameters that influence the production in greenhouse (Temperature, relative humidity of air and soil moisture). Several sensors and actuators are installed and connected to a management and acquisition card. These sensors provide relevant information that is used to control ventilation, heating and pump by SMS. The procedure used in our system provides the owner with a remote control avoiding the needed to perform the control actions on site. The developed system in this paper is ideally suited for agricultural greenhouses in Morocco. It is simple to be installed and used by farmers who do not have knowledge in computer skills. Besides, most people use

their cell phones to communicate and send messages. Thus, in our system, with a simple message, all farmers can control their greenhouses from a distance. They can know the status of their greenhouse climate at any time (temperature, humidity...) and can control actuators to adjust these parameters (fan, heater, vent, drip irrigation...). Thus, we have developed a graphical interface using LabVIEW software for the local acquisition, monitoring with PC and storage of all data through the card PCL812PG. The greenhouse industry is the fastest growing sector worldwide. The greenhouse separates the crop from the environment, thus providing some way of shelter from the direct influence of the external weather conditions (Tantau, 2003; Ruiz-Garcia, 2009). This enables the production of crops that otherwise could not be produced at that specific location. The greenhouse enclosure permits the manipulation of the crop environment. This asset allows the farmer to steer the cultivation in a desirable direction. It leads to higher crop yield, prolonged production period, better quality, and less use of protective chemicals. The added value per unit area in greenhouse crops is much higher than that in open-field cultivation. In

moderate climate zones, energy is needed, whereas in arid zones, the cooling and availability of water is of major concern (Baille et al, 2001; El Fadl et al, 1996). The use of materials and energy as well as crop yield and quality can be influenced by operating the adjustable components of greenhouse, such as heating and cooling inputs, window opening, drip irrigation, screening and CO<sub>2</sub> dosage. Hence, it can be expected that the way these controls are operated influences the final economic result (Campagne, 1997; Dussion, 1989; Choukrallah, 1996; Urban, 1997). To fully exploit the enhanced possibilities for crop and resource management in greenhouse, it is indispensable to adjust and control variables with a remote automatic controlling system via SMS by using the GSM (Adedjouma et al, 2006; Hayat Khiyal et al, 2009; Ramamurthy, 2010). This is because it is almost difficult for human being to manipulate and be present every day near the system. Indeed, remote communication systems are a major component of the policy of modernization and technology transfer, due to the increasing development of mobile telecommunications. Thinking about the telecommunications technology GSM, it comes immediately to mind: i) voice

communication; ii) sending and receiving SMS/MMS; and iii) mobile internet. It is obvious to think that in using these services provided by this technology, it is possible to control and monitor systems from a distance using the GSM network (Li et al, 2010; Pawlowski et al, 2009; Romaguera, 2010). Mobile communications are integrated-applications as useful and current as home automation, industrial applications for handling and remote monitoring of complex systems but also in security systems, and protect property and people. Most physical variables relevant in a greenhouse can be measured by automatic sensors. This holds for temperature, soil moisture, and relative humidity. The most important disturbance factors can be measured with sensors as well, that is, outside temperature, outside relative humidity, wind speed, and solar radiation. Precipitation can also be detected, although it is somewhat less common. All the mentioned physical variables are sampled and stored electronically at regular intervals when something is changing. Also, in principle, the control inputs are known, although it must be said that these important data are not always recorded. Overall, the measurements provide quite a good input-output picture of the physical part of the

greenhouse crop system. We propose a contribution to the development of greenhouse production in Morocco. This paper presents the design and development of an electronic system based on a microcontroller that integrates remote control functions rooted in the GSM network (Adedjouma et al, 2006). The system allows the acquisition of different climatic parameters in an agricultural greenhouse. In addition, this electronic system achieves the control and remote monitoring of greenhouse solutions, in particular drip irrigation stations, by sending SMS messages (Lajara et al, 2011; Luthra et al, 1997). The system, also, includes a serial cable, a GSM, conditional sensors card, power interfaces and microcontroller. An active SIM card is required to receive and send messages. We have developed a graphical user interface using LabVIEW software for the acquisition, monitoring with PC and storage of all data through the PCL812PG card. This interface encompasses at the same time reliability, flexibility of use, interactivity and processing capability in real-time of the whole data. Our systems present several advantages: i) user friendly; ii) easily implemented; iii) focus main parameters; iii)

use GSM phones because of their availability; iv) low cost of SMS in Morocco; and v) network coverage (3 operators existing in Morocco cover all the territory).

## **EXISTING SYSTEM**

The cultivation of plants under artificial environmental parameters is a cutting-edge approach that has revolutionized traditional agricultural practices. This system involves the use of controlled environments, such as greenhouses or indoor farming facilities, where various environmental factors like temperature, humidity, light, and nutrient levels are precisely regulated. By manipulating these parameters, farmers can create optimal conditions for plant growth throughout the year, independent of external weather patterns. This method not only extends the growing season but also enhances productivity rates significantly.

In this system, advanced technologies like automated climate control systems, hydroponics, and vertical farming techniques play crucial roles. Automated climate control systems allow farmers to maintain specific temperature and humidity ranges, ensuring that plants receive ideal conditions for photosynthesis and overall

development. Hydroponics, a soil-less cultivation method, enables precise nutrient delivery directly to plant roots, promoting efficient nutrient absorption and minimizing resource wastage. Additionally, vertical farming optimizes space utilization by stacking crops in vertical layers, thereby maximizing production per square meter.

Artificial lighting systems, often incorporating LED technology, are essential components of this cultivation approach. These systems provide the necessary light spectrum for different growth stages, promoting accelerated growth and consistent crop quality. Furthermore, the integration of smart sensors and data analytics allows farmers to monitor and adjust environmental parameters in real-time, optimizing resource usage and responding promptly to any deviations.

The benefits of cultivating plants under artificial environmental parameters are manifold. First and foremost, this approach enables year-round production, reducing dependency on seasonal variations. It also allows farmers to grow crops in regions with inhospitable climates, expanding agricultural possibilities. The controlled environment minimizes the risk of pests and diseases,

reducing the need for chemical interventions. Additionally, the efficient use of resources, such as water and nutrients, contributes to sustainability and environmental conservation.

In conclusion, the cultivation of plants under artificial environmental parameters represents a paradigm shift in agriculture, offering a sustainable and technology-driven solution to increase productivity rates. As technology continues to advance, this system holds great promise for meeting the growing global demand for food while mitigating the challenges posed by climate change and resource constraints.

## IMPLEMENTATION

### BLOCK DIAGRAM

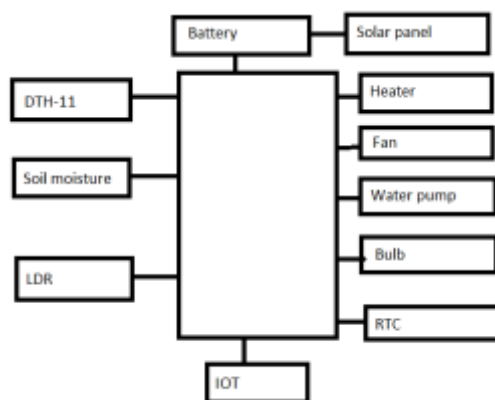

The proposed system for the cultivation of plants under artificial environmental parameters aims to revolutionize traditional agricultural practices and enhance productivity rates. By leveraging advanced technologies, such as controlled environment agriculture (CEA) and precision agriculture, this system seeks to create an optimized and tailored environment for plant growth.

In this innovative approach, key environmental factors such as temperature, humidity, light intensity, and nutrient levels will be meticulously monitored and controlled using sensor networks and automation systems. The integration of smart technologies will enable real-time adjustments to ensure that the plants receive optimal conditions throughout their growth cycles.

## CONCLUSION

A system that cultivate crops with the productivity rate being doubled has been developed successfully. This system is made automatic to provide constant microclimatic parameters. This constant supply of parameters provide plant's necessary

nutrients in surplus amount and this greenhouse protects crops from pests. This system can be used for small scale agriculture, providing the maximum yield of crops in reduced time. As a result of day-to-day progression, a better yield of this tomato plant was produced.

## REFERENCES

[1] C. Edwards, "What are the advantages of a greenhouse?" LIVESTRONG.COM, 14 July 2015

[2] Sun Rong-Gao, Sun De-Chao, "Greenhouse Temperature and Humidity Intelligent Control System", 'Proceeding of 3rd WSEAS international Conference on Circuits, Systems, Signal and Telecommunication'2009.

[3] Sumit, K; Mohit; K; Aswani, K. and Praneet, G. 2012. Monitoring and Control of Greenhouse Environment. B.Eng. Project, Department of Electrical and Electronics Engineering, Bharat Institute of Technology, Meerut, India.

[4] Humidity Sensor: Types of Humidity Sensors & Working Principle,<https://www.engineersgarage.com/articles/humiditysensor>.

[5] Rahali, A; Guerbaoui, M; Ed-dahhak, A; El Afou, Y; Tannouche, A; Lachhab, A. and Bouchikhi, B. 2011. Development of Data Acquisition and Greenhouse Control System based on GSM. International Journal of Engineering, Science and Technology, 3(8): 297-306.